

# DC Machines

- ▶ When a machine converts mechanical energy into electrical energy which is DC in nature, it is called as a **DC Generator**.

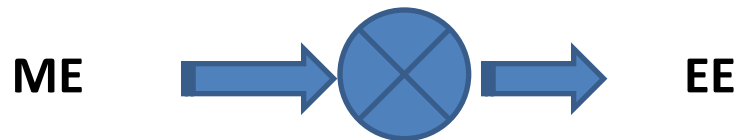

- ▶ Whenever a machine converts electrical energy which is DC in nature, into mechanical energy, it is called a **DC Motor**.

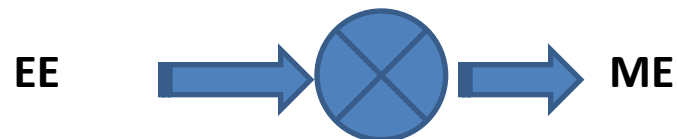

## Working Principle

- ▶ **Faraday's Laws of Electro magnetic Induction.**

Whenever a conductor cuts the flux of a magnetic field, an emf is produced in the conductor. If the two ends of the conductor are connected to an outside circuit, the induced emf causes current to flow in the circuit.

- ▶ The direction of induced current is given by **Fleming's right hand rule.**

# Single Turn Generator

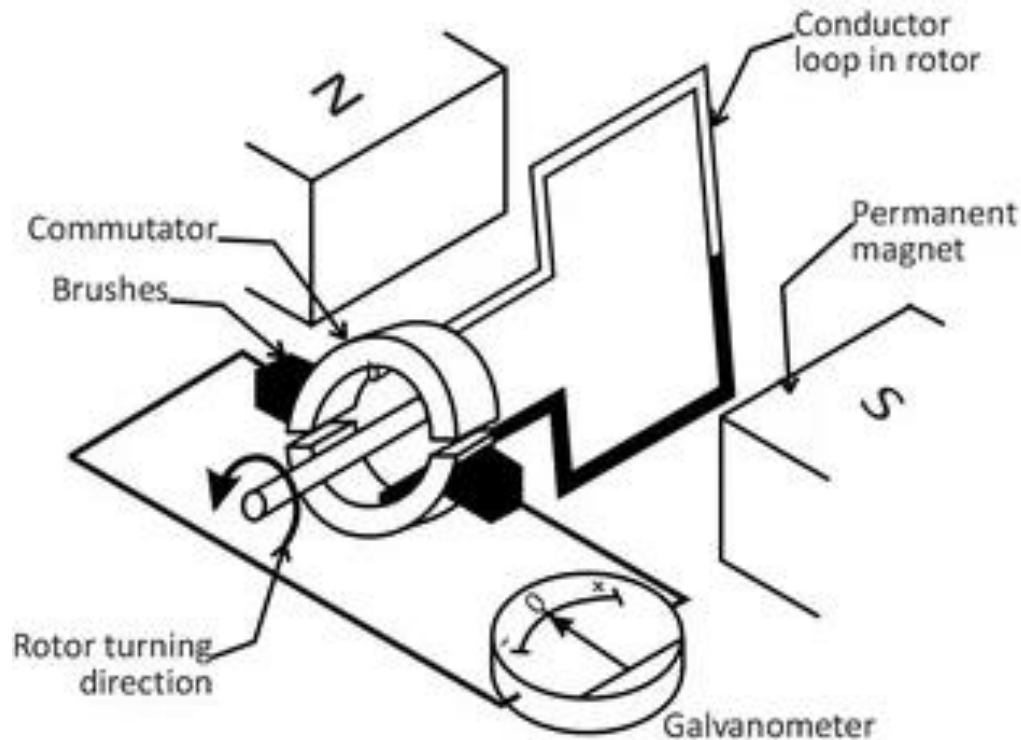

Consider a single turn coil rotating about its own axis in a magnetic field.  
The two ends of the coil are connected to split rings(commutator)

# Single Turn Generator

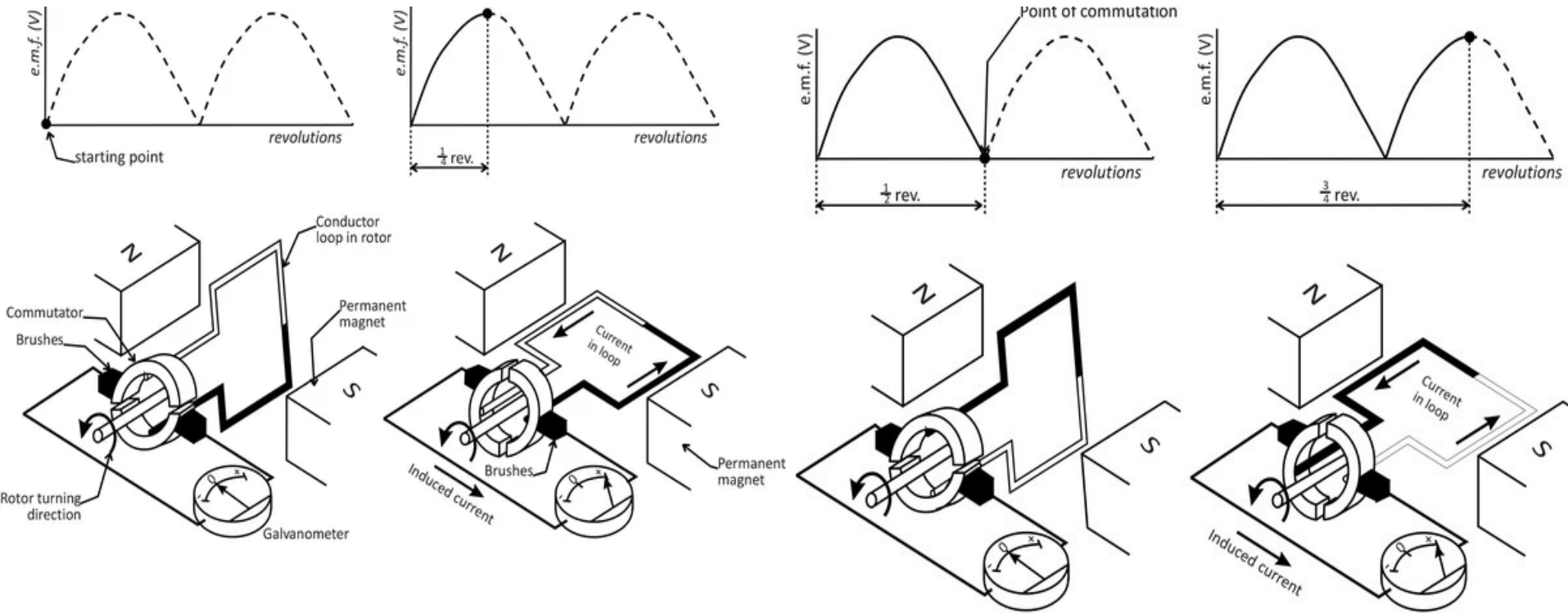

(a): One-loop generator at start of revolution    (b): One-loop generator at 1/4 revolution    (c): One-loop generator at 1/2 revolution    (d): One-loop generator at 3/4 revolution

- ▶ EMF induced in coil is proportional to rate of change of flux.
- ▶ When the plane of coil is at right angles to the direction of field, flux linked with coil is maximum, but rate of change of flux is minimum. Hence induced EMF is minimum.
- ▶ When the plane of coil is at parallel to the direction of field, flux linked with coil is minimum, but rate of change of flux is maximum. Hence induced EMF is maximum.
- ▶ In order to get a unidirectional current in external circuit, a split ring arrangement is done.

# Two Coil Generator

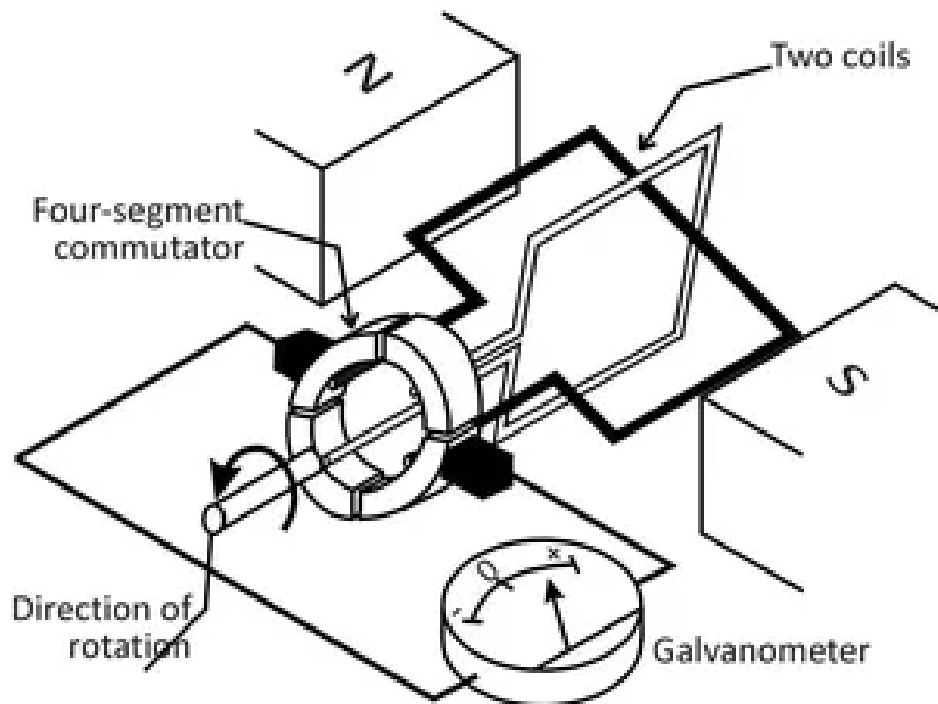

(a): Simple 2-coil DC generator

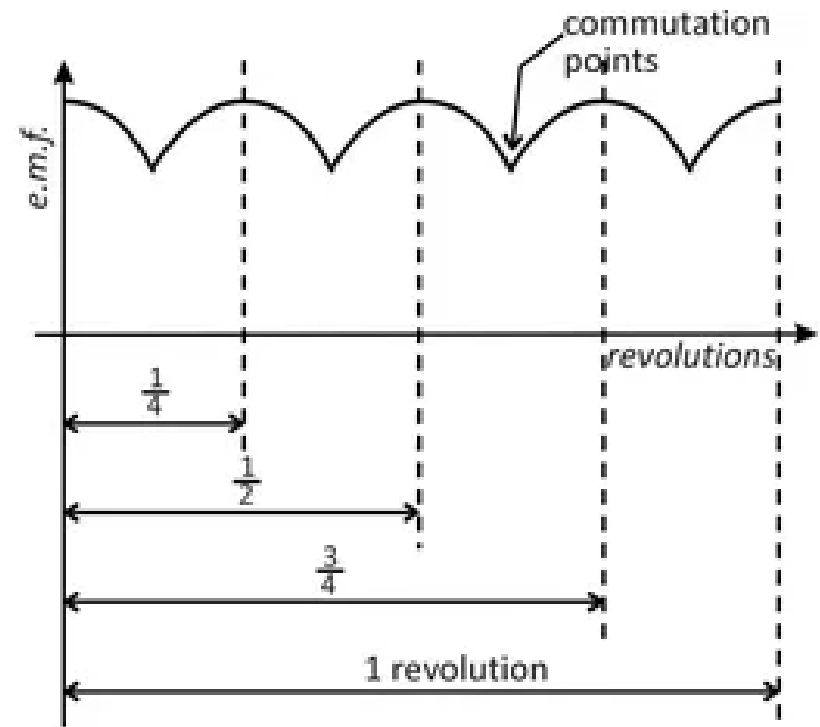

(b): E.m.f. developed by simple 2-coil DC generator

- By winding more coils on the rotor, and bringing the ends of each coil out to separate pair of segments on the commutator that are opposite each other, the pulsations or ripple in the output e.m.f. is reduced

## Construction

- ▶ Same for DC Generator and Motor
  
- ▶ A DC machine essentially consists of two parts.
  1. **Stator**(Stationary Part) – **Magnetic Field System**
  2. **Rotor**(Rotating Part) – **A system of conductors**

# DC Machine - Construction

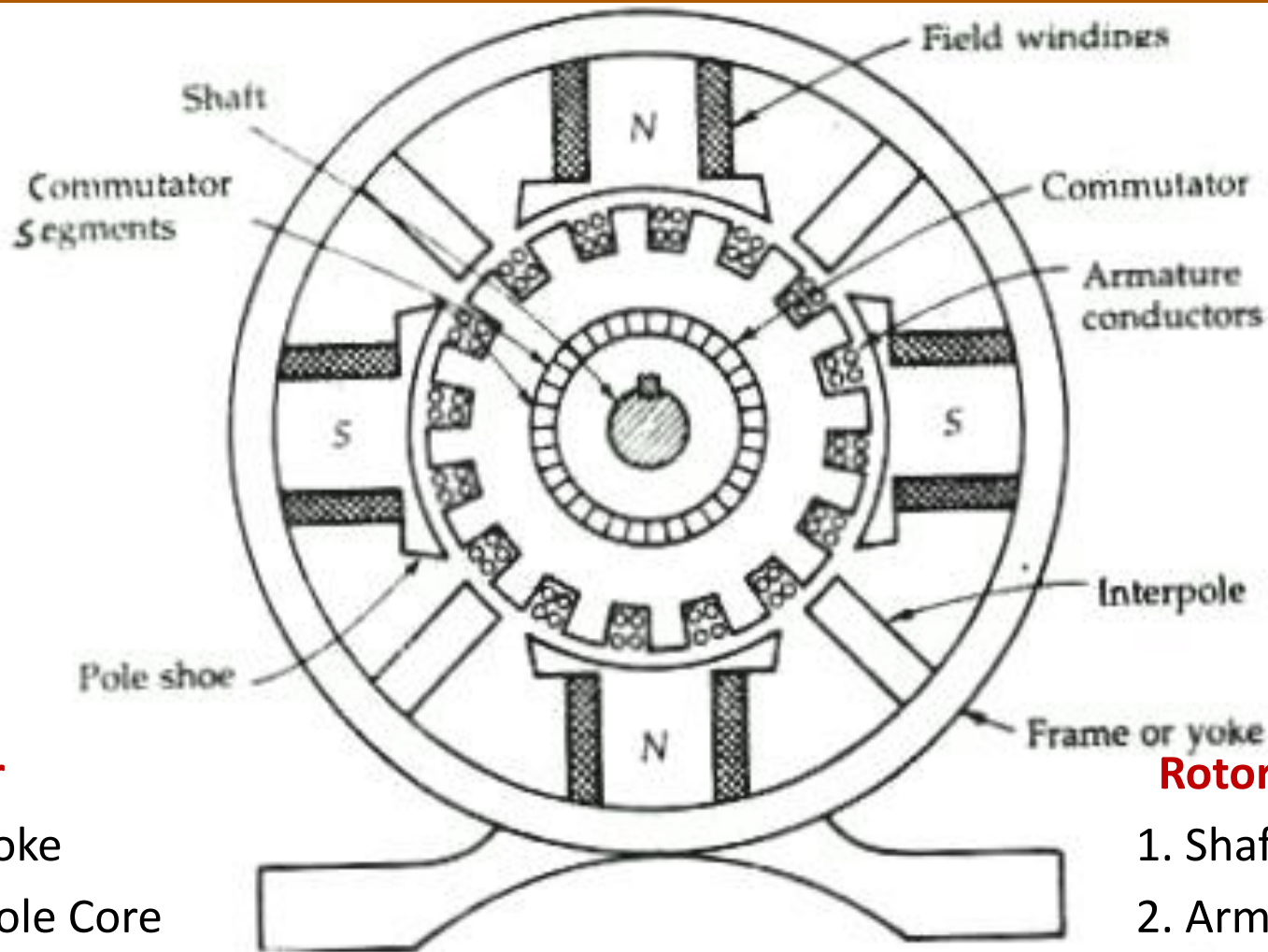

## Stator

1. Yoke
2. Pole Core
3. Pole Shoes
4. Field Coils
5. Interpoles

## Rotor

1. Shaft
2. Armature Core
3. Armature Windings
4. Commutator
5. Brushes

# DC Machine - Construction

## Yoke

- ▶ Hollow cylinder made of cast steel or roll steel
- ▶ Act as outer protective cover of machine.
- ▶ Provides mechanical support for poles.
- ▶ Carries flux produced by poles





# DC Machine - Construction

## Pole Core and Pole Shoes

- ▶ Field windings are wound on pole core and supported by pole shoes.
- ▶ Are made of number of sheet steels stacked and riveted together.

made of Silicon steel – to reduce hysteresis loss

laminated – to minimize eddy currents

- ▶ Pole cores are then bolted to yoke.
- ▶ Pole shoes serve two functions
  1. support field coils
  2. spread out flux in airgap

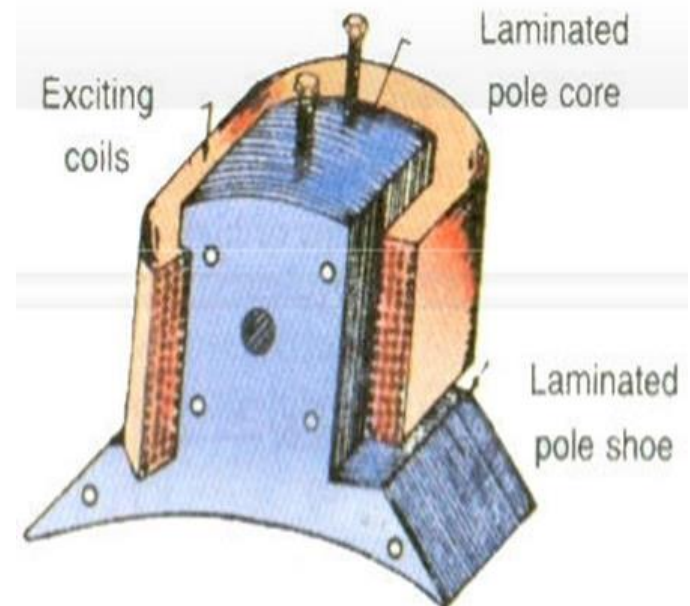

# DC Machine - Construction

## Field Windings

- ▶ are made of copper wire
- ▶ Field coils are former wound to correct dimension and then put into place over the core.
- ▶ When energized with DC, electro magnetize the poles and provide the working flux.
- ▶ All coils are connected in series such that as current flows, alternate N and S poles are produced.

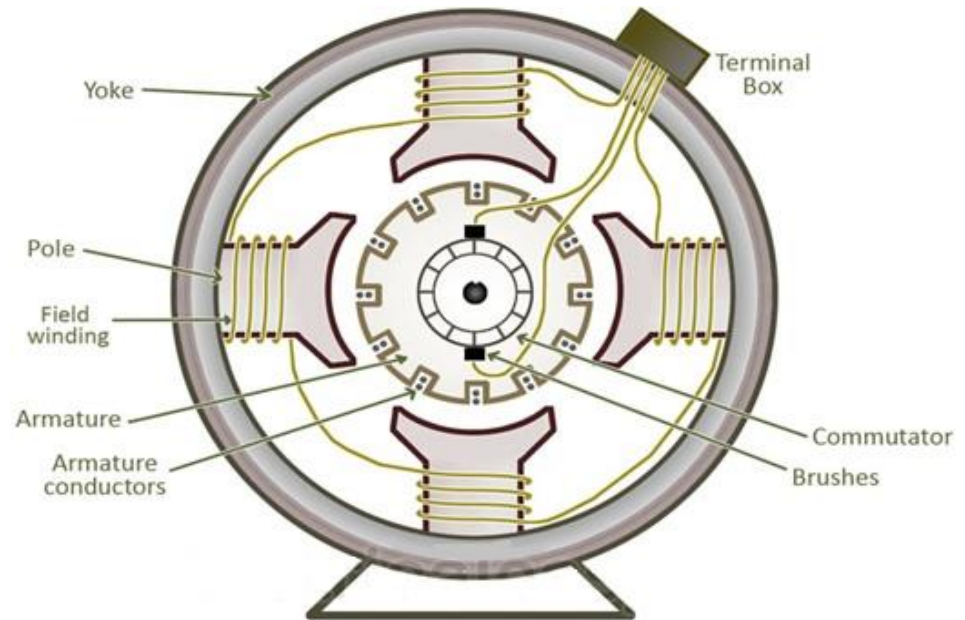

## Inter Poles

- ▶ Fitted to yoke between main poles.
- ▶ Windings are made of copper and are connected in series with field windings.
- ▶ Flux produced by inter poles provides **spark less commutation**.

# DC Machine - Construction

## Shaft

- ▶ Provides mechanical strength to armature and commutator.
- ▶ Rotor assembly is free to rotate by two bearing fixed between shaft and two end covers.
- ▶ Transfers mechanical energy to and from machine.

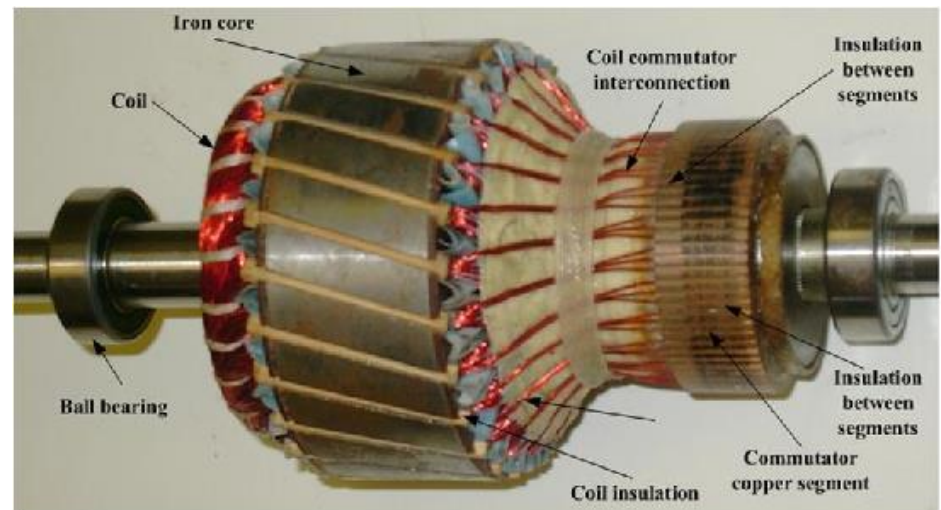

# DC Machine - Construction

## Armature Core and Windings

- ▶ Laminated cylinder mount on shaft.
- ▶ Are made of number of sheet steels stacked and riveted together.

made of Silicon steel – to reduce hysteresis loss

laminated – to minimize eddy currents

- ▶ Has slots on outer periphery to accommodate armature windings.

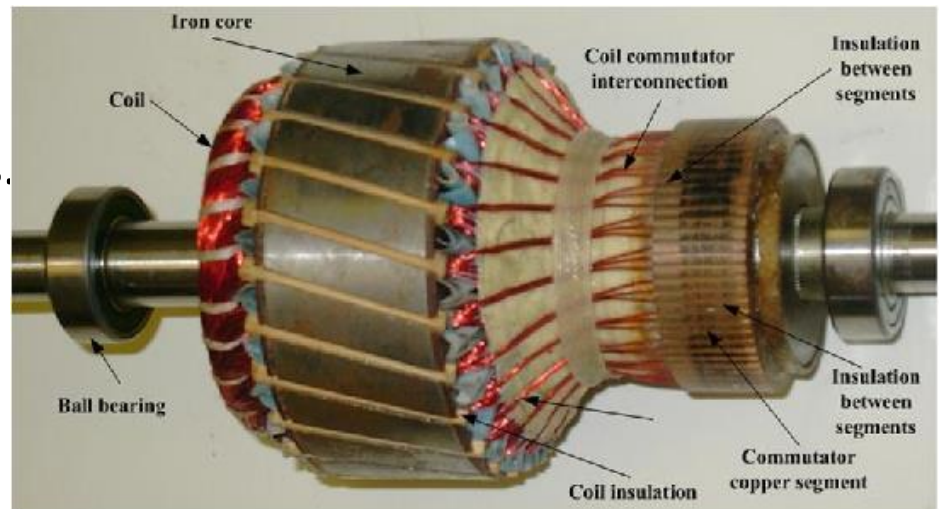

# DC Machine - Construction

## Commutator

- ▶ Ends of armature coils terminated at commutator segments
- ▶ Made of copper segments insulated by mica

## Functions

- ▶ Collect current from armature conductors.
- ▶ The e.m.f. generated in the armature conductors is alternating e.m.f. The commutator helps in converting this alternating e.m.f. into a direct one.

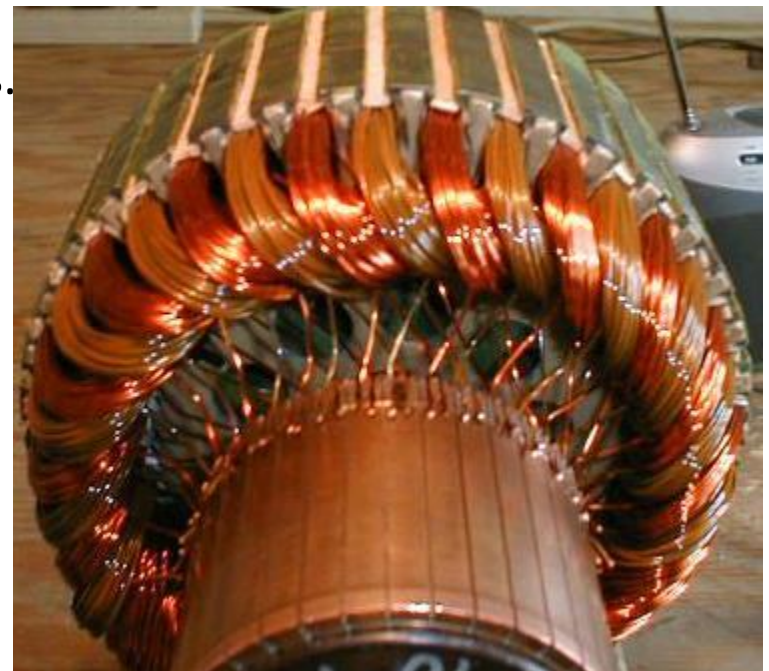

# DC Machine - Construction

## Brushes

- ▶ Made of graphite or carbon
- ▶ Held by brush holders

## Desirable Properties

- ▶ Good electrical conductivity
- ▶ Less co-efficient of friction.

## Functions

- ▶ The brushes collect the armature current from the commutator segments and supply it to the load (in the case of generator) or feed the current into the commutator segments (in the case of motor).

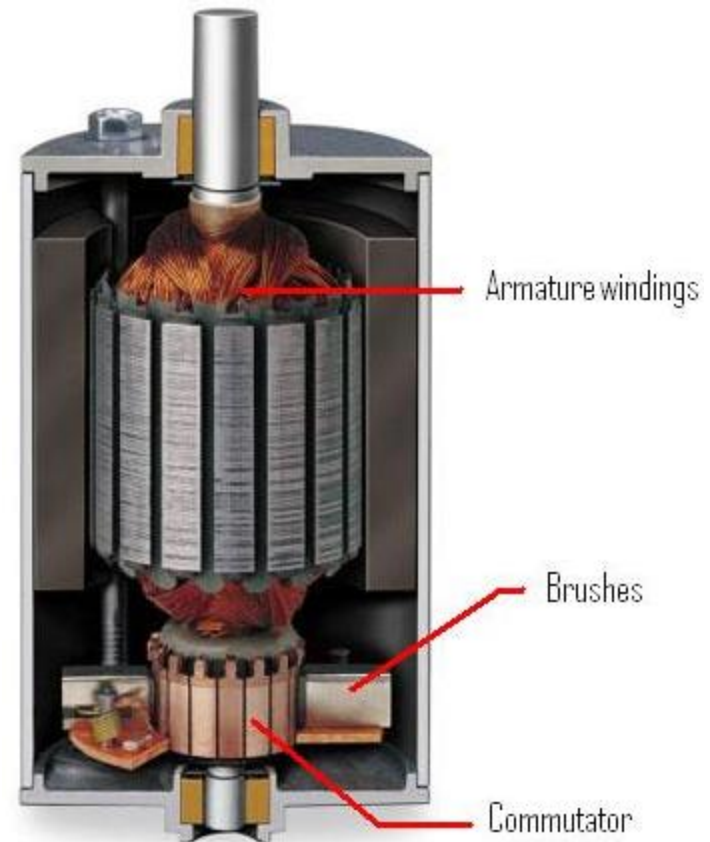

# DC Machine - Construction

## Wave Winding

- ▶ Armature winding is divided into two parallel paths.



## Lap Winding

- ▶ Armature winding is divided into as many parallel paths as number of poles of machine

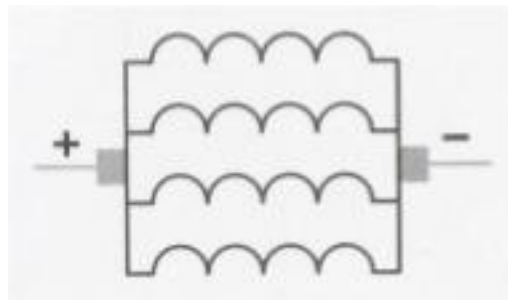



# DC Generator – EMF Equation

Let,

$\phi$  – useful flux per pole

Z – total number of conductors

P – number of poles

N – speed in rpm

A – number of parallel paths in armature

Flux cut by one conductor in one revolution =  $P\phi$

N rotations in 60 seconds, Time for one revolution =  $60/N$

$$\text{EMF induced in one conductor} = \frac{d\phi}{dt} = \frac{P\phi}{60/N} = \frac{P\phi N}{60}$$

$$\text{EMF induced in one parallel path} = \frac{P\phi N}{60} \frac{Z}{A}$$

# DC Motor

- ▶ Construction of dc motor is same as dc generator.

## Working Principle :

- ▶ When a current carrying conductor is placed in a magnetic field, the conductor experiences a mechanical force.
- ▶ The direction of this force is given by **Flemings Left Hand Rule**

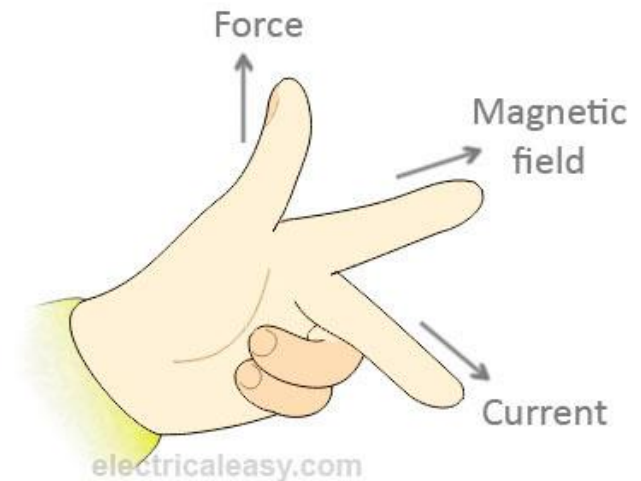

# DC Motor – Working Principle

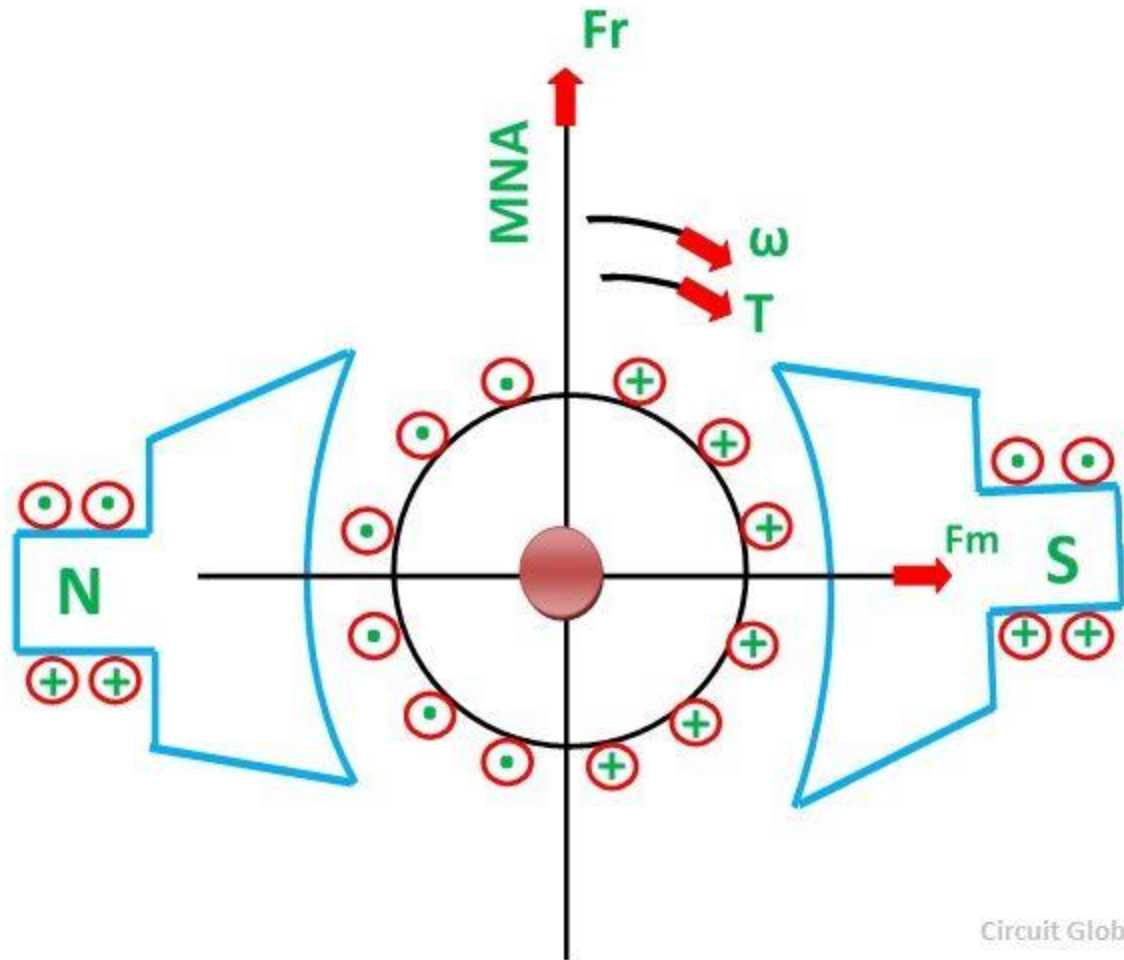

Circuit Globe

## DC Motor – Working Principle

- ▶ Consider a two polar DC motor as shown in figure. When motor terminals are connected to DC mains, field gets excited and alternate N-pole and S-pole is created. Armature conductors under N-pole carry current in one direction while conductor carry current in opposite direction as shown in figure.
- ▶ By applying Flemings left hand rule, the armature conductors experience a force which tends to rotate armature in clockwise direction. These forces collectively produce a driving torque which sets armature rotating.

## DC Motor – Back EMF

- ▶ When armature of dc motor rotates, the armature conductors move through the magnetic field, emf is induced in them. The induced emf acts in opposite direction to applied voltage. This voltage is known as back emf.

$$E_b = \frac{\phi Z N}{60} \frac{P}{A}$$

# DC Motor – Significance of Back EMF

1. Applied Voltage,  $V = I_a R_a + E_b$

This is known as voltage equation of DC Motor

$$I_a = \frac{V - E_b}{R_a}$$

Back EMF of DC motor controls the armature current.

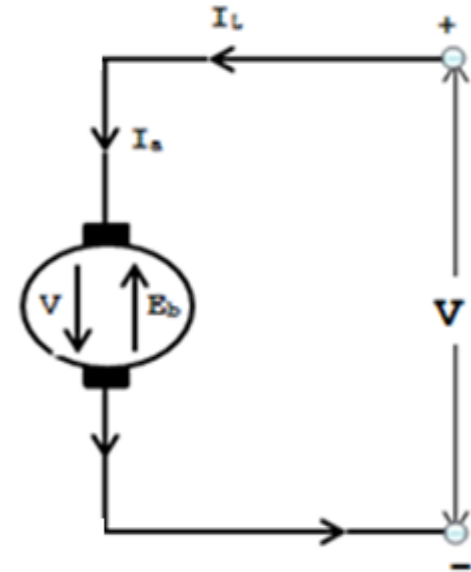

2. Multiplying voltage equation with  $I_a$

$$VI_a = I_a^2 R_a + E_b I_a$$

Power  $E_b I_a$  is converted to mechanical energy and transmitted through shaft.

# DC Motor – Necessity of Motor Starter

▶ Applied Voltage,  $V = I_a R_a + E_b$

$$I_a = \frac{V - E_b}{R_a}$$

▶ Back EMF,  $E_b = \frac{\phi Z N P}{60 A}$

▶ At starting motor is stationary  $N=0$ ,  $E_b = 0$ ,  $I_a = V/R_a$  is very high.

▶ High starting current causes:

1. Burning of armature due to excessive heating
2. Damage of commutator & brushes
3. Excessive voltage drop in line to which motor is connected.

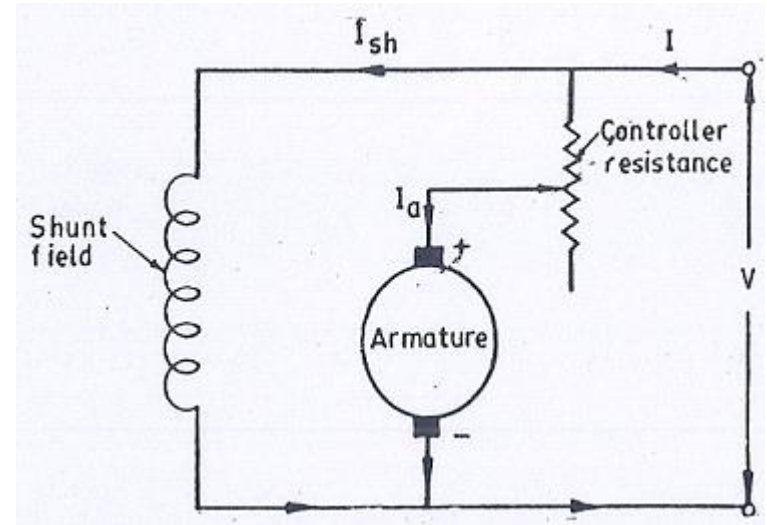

## DC Motor – Necessity of Motor Starter

- ▶ To avoid starting current, a variable resistance known as starting resistance is inserted in series with armature circuit as shown in figure. The resistance is gradually reduced as motor gains speed and is cut out completely after motor attains full speed.

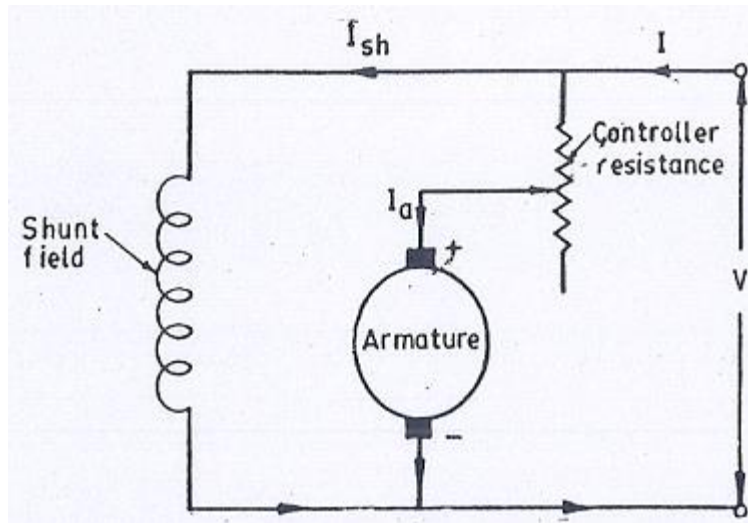



# DC Machine - Types

- ▶ Magnetic flux in DC machine is produced by field coils carrying current.  
This is called excitation.
- ▶ DC machines are classified based on type of excitation.
- ▶ Classification is same for DC Generator and Motor

# DC Machine - Types

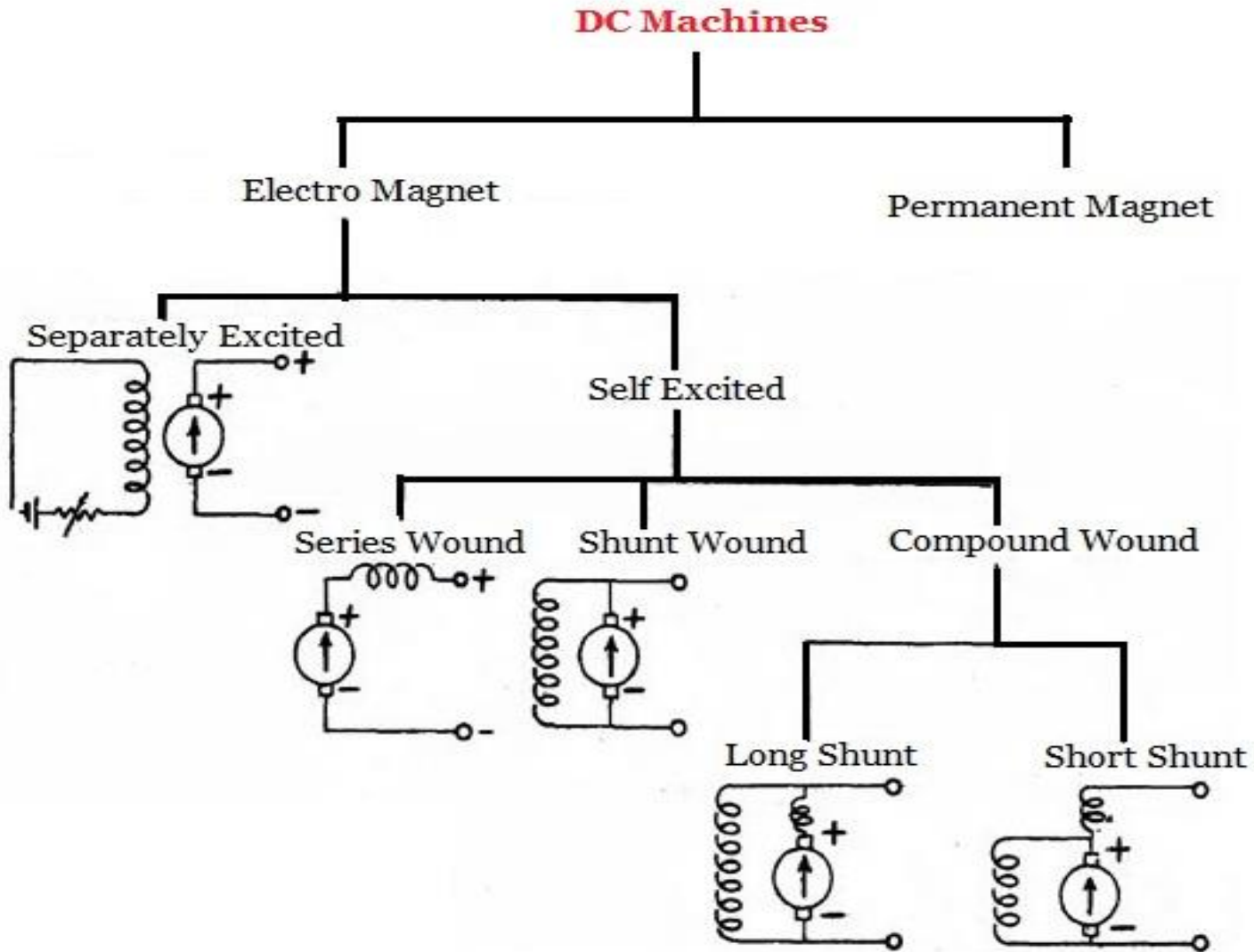

# Seperately Excited DC Motor

- ▶ Field winding is supplied from an independent external source

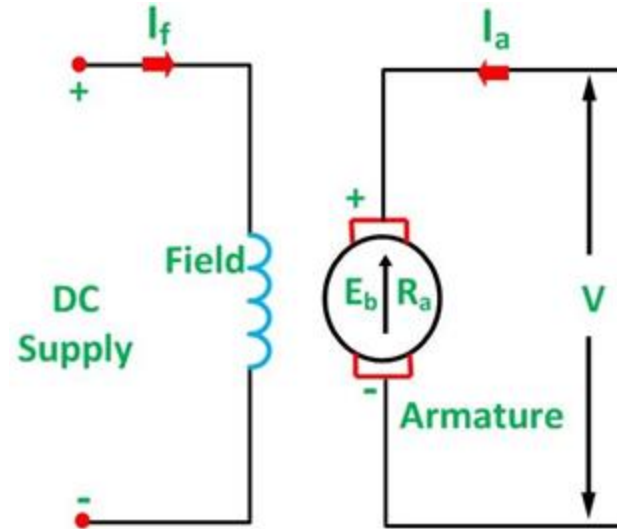

Armature Current,  $I_a = I_L$  (line current)

Terminal Voltage,  $V = E_b + I_a R_a$

Electrical Power Developed =  $E_b I_a$

Power Delivered to Load =  $V I_L$

# Shunt Wound DC Motor

- ▶ Field winding is connected in parallel with armature winding.
- ▶ Shunt field winding is generally made of large no. of turns of fine wire having high resistance.

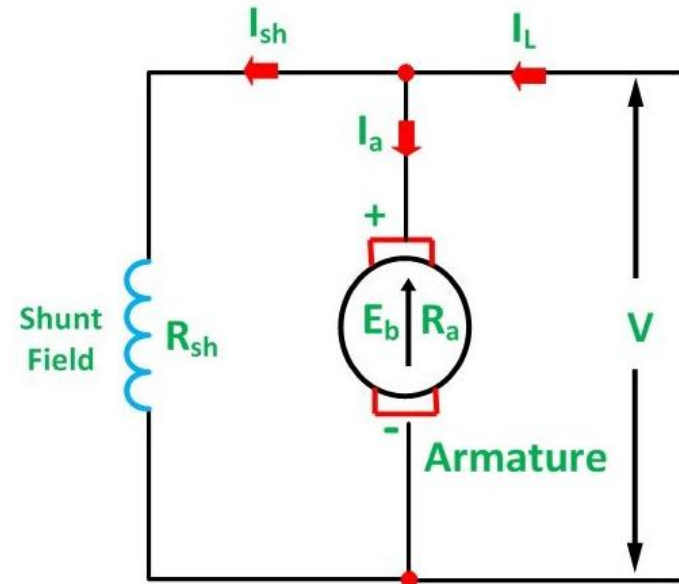

Armature Current,  $I_a = I_L - I_{sh}$

Field Current,  $I_{sh} = V/R_{sh}$

Terminal Voltage,  $V = E_b + I_a R_a$

Electrical Power Developed =  $E_b I_a$

Power Delivered to Load =  $V I_L$

# Series Wound DC Motor

- ▶ Field winding is connected in series with armature winding.
- ▶ Shunt field winding is generally made of few turns of wire with large cross-sectional area.

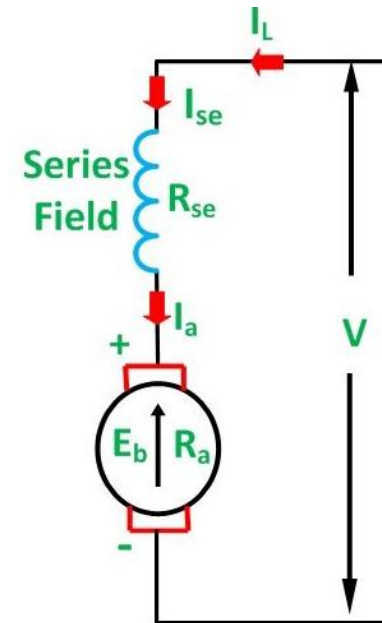

Armature Current,  $I_a = I_{se} = I_L$

Terminal Voltage,  $V = E_b + I_a R_a + I_{se} R_{se}$

Electrical Power Developed =  $E_b I_a$

Power Delivered to Load =  $V I_L$

# Compound Wound DC Motor

- ▶ Has both series and shunt field windings.
- ▶ Each pole carries both series winding and shunt winding.
- ▶ Two types:
  1. Long Shunt compound Motor
  2. Short Shunt compound Motor

# Compound Wound DC Motor – Long Shunt

- ▶ Shunt field winding is connected in parallel with series field winding and armature winding.

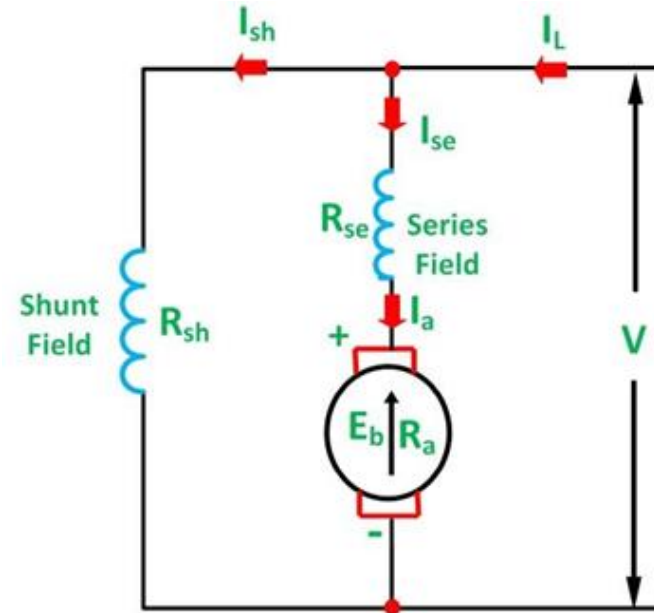

Armature Current,  $I_a = I_L - I_{sh} = I_{se}$

Field Current,  $I_{sh} = V/R_{sh}$

Terminal Voltage,  $V = E_b + I_a R_a + I_{se} R_{se}$

Electrical Power Developed =  $E_b I_a$

Power Delivered to Load =  $V I_L$

# Compound Wound DC Motor – Short Shunt

- ▶ Shunt field winding is connected in parallel with armature winding only.

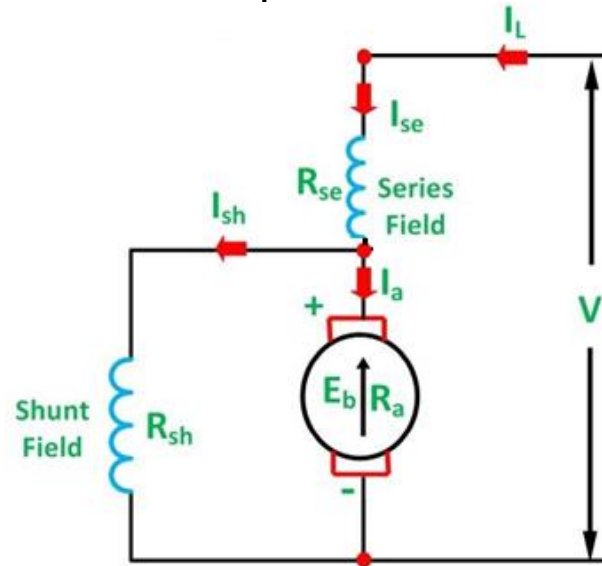

Armature Current,  $I_a = I_L - I_{sh}$

Field Current,  $I_{sh} = (V - I_{se} R_{se}) / R_{sh}$

Terminal Voltage,  $V = E_b + I_a R_a + I_{se} R_{se} = I_{sh} R_{sh}$

Electrical Power Developed =  $E_b I_a$

Power Delivered to Load =  $V I_L$



# Compound Wound DC Motor – Differentially Compounded and Cumulatively Compounded

## Cumulatively Compounded

- ▶ When series field aids the shunt field, motor is said to cumulatively compounded.

## Differentially Compounded

- ▶ When series field opposes the shunt field, motor is said to differentially compounded.

# Applications of DC Motor

## 1. Shunt Motor

- ▶ Constant speed motor.
- ▶ Used in lathe, drills, boring mills, spinning and weaving mills etc.

## 2. Series Motor

- ▶ Variable speed motor, high starting torque.
- ▶ Used in elevators, electric traction, cranes, vaccum cleaners etc.

## 3. Compound Motor

- ▶ Differentially compound motor—rarely used
- ▶ Cumulatively compound motor – used in presses, reciprocating machines, etc.